



MICROCHIP

**CAN Bus Analyzer
User's Guide**

Note the following details of the code protection feature on Microchip products:

- Microchip products meet the specifications contained in their particular Microchip Data Sheet.
- Microchip believes that its family of products is secure when used in the intended manner, within operating specifications, and under normal conditions.
- Microchip values and aggressively protects its intellectual property rights. Attempts to breach the code protection features of Microchip product is strictly prohibited and may violate the Digital Millennium Copyright Act.
- Neither Microchip nor any other semiconductor manufacturer can guarantee the security of its code. Code protection does not mean that we are guaranteeing the product is “unbreakable”. Code protection is constantly evolving. Microchip is committed to continuously improving the code protection features of our products.

This publication and the information herein may be used only with Microchip products, including to design, test, and integrate Microchip products with your application. Use of this information in any other manner violates these terms. Information regarding device applications is provided only for your convenience and may be superseded by updates. It is your responsibility to ensure that your application meets with your specifications. Contact your local Microchip sales office for additional support or, obtain additional support at <https://www.microchip.com/en-us/support/design-help/client-support-services>.

THIS INFORMATION IS PROVIDED BY MICROCHIP "AS IS". MICROCHIP MAKES NO REPRESENTATIONS OR WARRANTIES OF ANY KIND WHETHER EXPRESS OR IMPLIED, WRITTEN OR ORAL, STATUTORY OR OTHERWISE, RELATED TO THE INFORMATION INCLUDING BUT NOT LIMITED TO ANY IMPLIED WARRANTIES OF NON-INFRINGEMENT, MERCHANTABILITY, AND FITNESS FOR A PARTICULAR PURPOSE, OR WARRANTIES RELATED TO ITS CONDITION, QUALITY, OR PERFORMANCE.

IN NO EVENT WILL MICROCHIP BE LIABLE FOR ANY INDIRECT, SPECIAL, PUNITIVE, INCIDENTAL, OR CONSEQUENTIAL LOSS, DAMAGE, COST, OR EXPENSE OF ANY KIND WHATSOEVER RELATED TO THE INFORMATION OR ITS USE, HOWEVER CAUSED, EVEN IF MICROCHIP HAS BEEN ADVISED OF THE POSSIBILITY OR THE DAMAGES ARE FORESEEABLE. TO THE FULLEST EXTENT ALLOWED BY LAW, MICROCHIP'S TOTAL LIABILITY ON ALL CLAIMS IN ANY WAY RELATED TO THE INFORMATION OR ITS USE WILL NOT EXCEED THE AMOUNT OF FEES, IF ANY, THAT YOU HAVE PAID DIRECTLY TO MICROCHIP FOR THE INFORMATION.

Use of Microchip devices in life support and/or safety applications is entirely at the buyer's risk, and the buyer agrees to defend, indemnify and hold harmless Microchip from any and all damages, claims, suits, or expenses resulting from such use. No licenses are conveyed, implicitly or otherwise, under any Microchip intellectual property rights unless otherwise stated.

For information regarding Microchip's Quality Management Systems, please visit www.microchip.com/quality.

Trademarks

The Microchip name and logo, the Microchip logo, Adaptec, AnyRate, AVR, AVR logo, AVR Freaks, BesTime, BitCloud, CryptoMemory, CryptoRF, dsPIC, flexPWR, HELDO, IGLOO, JukeBlox, KeeLoq, Kleer, LANCheck, LinkMD, maxStylus, maXTouch, MediaLB, megaAVR, Microsemi, Microsemi logo, MOST, MOST logo, MPLAB, OptoLyzer, PIC, picoPower, PICSTART, PIC32 logo, PolarFire, Prochip Designer, QTouch, SAM-BA, SenGenuity, SpyNIC, SST, SST Logo, SuperFlash, Symmetricom, SyncServer, Tachyon, TimeSource, tinyAVR, UNI/O, Vectron, and XMEGA are registered trademarks of Microchip Technology Incorporated in the U.S.A. and other countries.

AgileSwitch, APT, ClockWorks, The Embedded Control Solutions Company, EtherSynch, Flashtec, Hyper Speed Control, HyperLight Load, IntelliMOS, Libero, motorBench, mTouch, Powermite 3, Precision Edge, ProASIC, ProASIC Plus, ProASIC Plus logo, QuietWire, SmartFusion, SyncWorld, Temux, TimeCesium, TimeHub, TimePictra, TimeProvider, TrueTime, WinPath, and ZL are registered trademarks of Microchip Technology Incorporated in the U.S.A.

Adjacent Key Suppression, AKS, Analog-for-the-Digital Age, Any Capacitor, AnyIn, AnyOut, Augmented Switching, BlueSky, BodyCom, CodeGuard, CryptoAuthentication, CryptoAutomotive, CryptoCompanion, CryptoController, dsPICDEM, dsPICDEM.net, Dynamic Average Matching, DAM, ECAN, Espresso T1S, EtherGREEN, GridTime, IdealBridge, In-Circuit Serial Programming, ICSP, INICnet, Intelligent Paralleling, Inter-Chip Connectivity, JitterBlocker, Knob-on-Display, maxCrypto, maxView, memBrain, Mindi, MiWi, MPASM, MPF, MPLAB Certified logo, MPLIB, MPLINK, MultiTRAK, NetDetach, NVM Express, NVMe, Omniscient Code Generation, PICDEM, PICDEM.net, Pickit, PICTail, PowerSmart, PureSilicon, QMatrix, REAL ICE, Ripple Blocker, RTAX, RTG4, SAM-ICE, Serial Quad I/O, simpleMAP, SimpliPHY, SmartBuffer, SmartHLS, SMART-I.S., storClad, SQL, SuperSwitcher, SuperSwitcher II, Switchtec, SynchroPHY, Total Endurance, TSHARC, USBCheck, VariSense, VectorBlox, VeriPHY, ViewSpan, WiperLock, XpressConnect, and ZENA are trademarks of Microchip Technology Incorporated in the U.S.A. and other countries.

SQTP is a service mark of Microchip Technology Incorporated in the U.S.A.

The Adaptec logo, Frequency on Demand, Silicon Storage Technology, Symmcom, and Trusted Time are registered trademarks of Microchip Technology Inc. in other countries.

GestIC is a registered trademark of Microchip Technology Germany II GmbH & Co. KG, a subsidiary of Microchip Technology Inc., in other countries.

All other trademarks mentioned herein are property of their respective companies.

© 2009-2022, Microchip Technology Incorporated and its subsidiaries.

All Rights Reserved.

ISBN: 978-1-6683-0344-3



CAN BUS ANALYZER USER'S GUIDE

Table of Contents

Preface	5
Introduction.....	5
Document Layout	5
Conventions Used in this Guide	6
Recommended Reading.....	7
The Microchip Website	7
Product Change Notification Service.....	7
Customer Support	8
Document Revision History	8
Chapter 1. Introduction	9
1.1 Introduction	9
1.2 Can Bus Analyzer Kit Contents	9
1.3 Overview of the CAN Bus Analyzer	9
1.4 CAN Bus Analyzer Hardware Features	10
1.5 CAN Bus Analyzer Software	12
Chapter 2. Installation	13
2.1 Introduction	13
2.2 Software Installation	13
2.3 Hardware Installation	14
Chapter 3. Using the PC GUI	17
3.1 Getting Started with a Quick Setup	17
3.2 Trace Feature	18
3.3 Transmit Feature	19
3.4 Hardware Setup Feature	20
Appendix A. Error Messages	21
Worldwide Sales and Service	24

CAN Bus Analyzer User's Guide

NOTES:

Preface

NOTICE TO CUSTOMERS

All documentation becomes dated, and this manual is no exception. Microchip tools and documentation are constantly evolving to meet customer needs, so some actual dialogs and/or tool descriptions may differ from those in this document. Please refer to our website (www.microchip.com) to obtain the latest documentation available.

Documents are identified with a “DS” number. This number is located on the bottom of each page, in front of the page number. The numbering convention for the DS number is “DSXXXXXXXXA”, where “XXXXXXXX” is the document number and “A” is the revision level of the document.

For the most up-to-date information on development tools, see the MPLAB® IDE on-line help. Select the Help menu, and then Topics to open a list of available on-line help files.

INTRODUCTION

This chapter contains general information that will be useful to know before using the Chapter Name. Items discussed in this chapter include:

- [Document Layout](#)
- [Conventions Used in this Guide](#)
- [Recommended Reading](#)
- [The Microchip Website](#)
- [Product Change Notification Service](#)
- [Customer Support](#)
- [Document Revision History](#)

DOCUMENT LAYOUT

This user's guide describes how to use the Chapter Name as a development tool to emulate and debug firmware on a target board. The topics discussed in this preface include:

- [Chapter 1. “Introduction”](#)
- [Chapter 2. “Installation”](#)
- [Chapter 3. “Using the PC GUI”](#)
- [Appendix A. “Error Messages”](#)

CAN Bus Analyzer User's Guide

CONVENTIONS USED IN THIS GUIDE

This manual uses the following documentation conventions:

DOCUMENTATION CONVENTIONS

Description	Represents	Examples
Arial font:		
Italic characters	Referenced books	<i>MPLAB[®] IDE User's Guide</i>
	Emphasized text	...is the <i>only</i> compiler...
Initial caps	A window	the Output window
	A dialog	the Settings dialog
	A menu selection	select Enable Programmer
Quotes	A field name in a window or dialog	"Save project before build"
Underlined, italic text with right angle bracket	A menu path	<u><i>File>Save</i></u>
Bold characters	A dialog button	Click OK
	A tab	Click the Power tab
N'Rnnnn	A number in verilog format, where N is the total number of digits, R is the radix and n is a digit.	4'b0010, 2'hF1
Text in angle brackets < >	A key on the keyboard	Press <Enter>, <F1>
Courier New font:		
Plain Courier New	Sample source code	#define START
	Filenames	autoexec.bat
	File paths	c:\mcc18\h
	Keywords	_asm, _endasm, static
	Command-line options	-Opa+, -Opa-
	Bit values	0, 1
	Constants	0xFF, 'A'
Italic Courier New	A variable argument	<i>file.o</i> , where <i>file</i> can be any valid filename
Square brackets []	Optional arguments	mcc18 [options] <i>file</i> [options]
Curly brackets and pipe character: { }	Choice of mutually exclusive arguments; an OR selection	errorlevel {0 1}
Ellipses...	Replaces repeated text	<i>var_name</i> [, <i>var_name</i> ...]
	Represents code supplied by user	<i>void main (void)</i> { ... }

RECOMMENDED READING

This user's guide describes how to use the CAN Bus Analyzer on a CAN network. The following Microchip documents are available on www.microchip.com and are recommended as supplemental reference resources to understand CAN (Controller Area Network) more thoroughly.

AN713, Controller Area Network (CAN) Basics (DS00713)

This application note describes the basics and key features of the CAN protocol.

AN228, A CAN Physical Layer Discussion (DS00228)

AN754, Understanding Microchip's CAN Module Bit Timing (DS00754)

These application notes discuss the MCP2551 CAN transceiver and how it fits within the ISO 11898 specification. ISO 11898 specifies the physical layer to ensure compatibility between CAN transceivers.

CAN Design Center

Visit the CAN design center on Microchip's website (www.microchip.com/CAN) for information on the latest product information and new application notes.

THE MICROCHIP WEBSITE

Microchip provides online support via our website at www.microchip.com. This website is used as a means to make files and information easily available to customers. Accessible by using your favorite Internet browser, the website contains the following information:

- **Product Support** – Data sheets and errata, application notes and sample programs, design resources, user's guides and hardware support documents, latest software releases and archived software
- **General Technical Support** – Frequently Asked Questions (FAQs), technical support requests, online discussion groups, Microchip consultant program member listing
- **Business of Microchip** – Product selector and ordering guides, latest Microchip press releases, listing of seminars and events, listings of Microchip sales offices, distributors and factory representatives

PRODUCT CHANGE NOTIFICATION SERVICE

Microchip's customer notification service helps keep customers current on Microchip products. Subscribers will receive e-mail notification whenever there are changes, updates, revisions or errata related to a specified product family or development tool of interest.

To register, access the Microchip website at www.microchip.com, click on Product Change Notification and follow the registration instructions.

CAN Bus Analyzer User's Guide

CUSTOMER SUPPORT

Users of Microchip products can receive assistance through several channels:

- Distributor or Representative
- Local Sales Office
- Field Application Engineer (FAE)
- Technical Support

Customers should contact their distributor, representative or FAE for support. Local sales offices are also available to help customers. A listing of sales offices and locations is included in the back of this document.

Technical support is available through the website at: <http://support.microchip.com>.

DOCUMENT REVISION HISTORY

Revision A (July 2009)

- Initial Release of this Document.

Revision B (October 2011)

- Updated Sections 1.1, 1.3, 1.4 and 2.3.2. Updated the figures in Chapter 3, and updated Sections 3.2, 3.8 and 3.9.

Revision C (November 2020)

- Removed Sections 3.4, 3.5, 3.6 and 3.8.
- Updated [Chapter 1. "Introduction"](#), [Section 1.5 "CAN Bus Analyzer Software"](#) and [Section 3.2 "Trace Feature"](#).
- Typographical edits throughout document.

Revision C (February 2022)

- Updated [Section 1.4 "CAN Bus Analyzer Hardware Features "](#).

Revision D (April 2022)

- Updated [Section 1.4 "CAN Bus Analyzer Hardware Features "](#).
- Typographical edits throughout document.

Chapter 1. Introduction

1.1 INTRODUCTION

The CAN Bus Analyzer tool is intended to be a simple-to-use, low-cost CAN Bus monitor, which can be used to develop and debug a high-speed CAN network. The tool features a broad range of functions, which allow it to be used across various market segments, including automotive, marine, industrial and medical.

The CAN Bus Analyzer tool supports CAN 2.0b and ISO 11898-2 (high-speed CAN with transmission rates of up to 1 Mbit/s). The tool can be connected to the CAN network using the DB9 connector or through a screw terminal interface.

The CAN Bus Analyzer has the standard functionality expected in an industry tool, such as trace and transmit windows. All of these features make it a very versatile tool, allowing fast and simple debugging in any high-speed CAN network.

The chapter contains the following information:

- [Can Bus Analyzer Kit Contents](#)
- [Overview of the CAN Bus Analyzer](#)
- [CAN Bus Analyzer Hardware Features](#)
- [CAN Bus Analyzer Software](#)

1.2 CAN BUS ANALYZER KIT CONTENTS

1. CAN Bus Analyzer Hardware
2. CAN Bus Analyzer Software
3. CAN Bus Analyzer software CD, which includes three components:
 - Firmware for the PIC18F2550 (Hex File)
 - Firmware for the PIC18F2680 (Hex File)
 - The CAN Bus Analyzer PC Graphical User Interface (GUI)
4. USB mini-cable to connect the CAN Bus Analyzer to the PC

1.3 OVERVIEW OF THE CAN BUS ANALYZER

The CAN Bus Analyzer provides similar features available in a high-end CAN network analyzer tool at a fraction of the cost. The CAN Bus Analyzer tool can be used to monitor and debug a CAN network with an easy-to-use Graphical User Interface. The tool allows the user to view and log received and transmitted messages from the CAN Bus. The user is also able to transmit single or periodic CAN messages onto a CAN Bus, which is useful during development or testing of a CAN network.

Using this CAN Bus Analyzer tool has many advantages over the traditional debugging methods embedded engineers typically rely on. For example, the tool trace window will show the user the received and transmitted CAN messages in an easy to read format (ID, DLC, data bytes and timestamp).

CAN Bus Analyzer User's Guide

1.4 CAN BUS ANALYZER HARDWARE FEATURES

The CAN Bus Analyzer hardware is a compact tool that includes the following hardware features. Refer to [Section 1.5 “CAN Bus Analyzer Software”](#) for more information about the software features.

FIGURE 1-1: CAN BUS ANALYZER

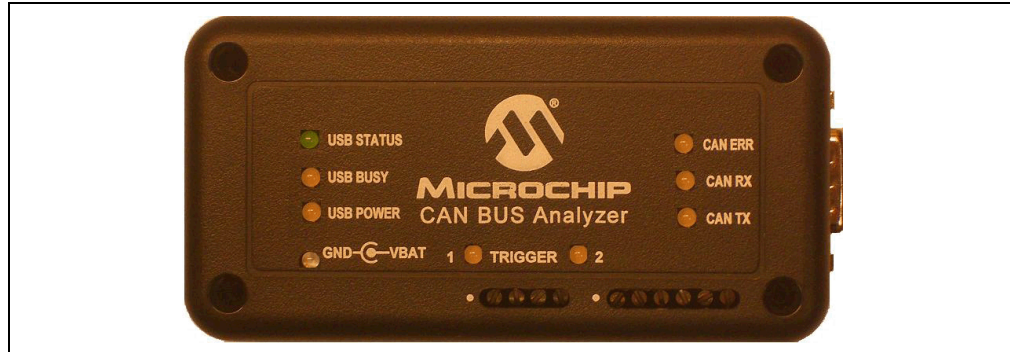

- Mini-USB Connector
This connector provides the CAN Bus Analyzer a communication medium to the PC, but it can also provide a power supply if the external power supply is not plugged into the CAN Bus Analyzer.
- 9-24 Volt Power Supply Connector
- DB9 Connector for the CAN Bus
- Termination Resistor (software controllable)
The user can turn on or off the 120 Ohm CAN Bus termination through the PC GUI.
- Status LEDs
Displays the USB status.
- CAN Traffic LEDs
Shows the actual RX CAN Bus traffic from the high-speed transceiver.
Shows the actual TX CAN Bus traffic from the high-speed transceiver.
- CAN Bus Error LED
Shows the Error Active (Green), Error Passive (Yellow), Bus Off (Red) state of the CAN Bus Analyzer.
- Direct Access to the CANH and CANL Pins through a Screw Terminal
Allows the user access to the CAN Bus for connecting an oscilloscope without having to modify the CAN Bus wire harness.
- Direct Access to the CAN TX and CAN RX Pins through a Screw Terminal
Allows the user access to the digital side of the CAN Bus transceiver.

FIGURE 1-2: CAN BUS ANALYZER SCHEMATIC

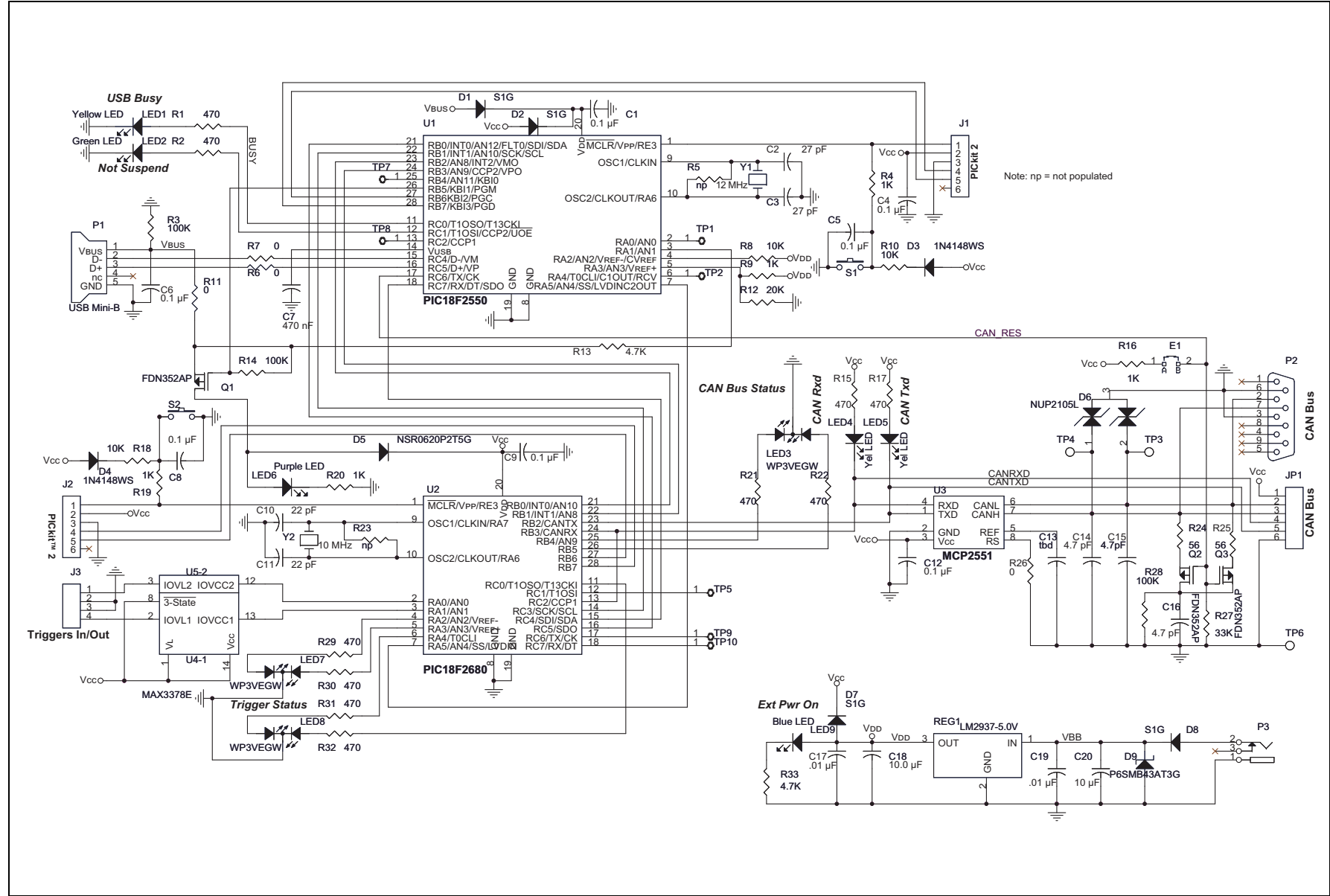

Note: np = not populated

CAN Bus Analyzer User's Guide

1.5 CAN BUS ANALYZER SOFTWARE

The CAN Bus Analyzer comes with two firmware Hex files and PC software which provide the user with a graphical interface to configure the tool, and analyze a CAN network. It has the following software tool features:

1. Trace: Monitor the CAN Bus traffic.
2. Transmit: Transmit single-shot, periodic or periodic messages with a limited repeat onto the CAN Bus.
3. Log File Setup: Save CAN Bus traffic.
4. Hardware Setup: Configure the CAN Bus Analyzer for the CAN network.

Chapter 2. Installation

2.1 INTRODUCTION

The following chapter describes the procedures for installing the CAN Bus Analyzer hardware and software.

This chapter contains the following information:

- [Software Installation](#)
- [Hardware Installation](#)

2.2 SOFTWARE INSTALLATION

2.2.1 Installing the GUI

Install .NET Framework Version 3.5 before installing the CAN Bus Analyzer.

1. Run "CANAnalyzer_verXYZ.exe", where "XYZ" is the version number of the software. By default, this will install the files to: C:\Program Files\Microchip Technology Inc\CANAnalyzer_verXYZ.
2. Run the setup.exe from folder: C:\Program Files\Microchip Technology Inc\CANAnalyzer_verXYZ\GUI.
3. The setup will create a shortcut in the Programs menu under "Microchip Technology Inc" as Microchip CAN Tool ver XYZ.
4. If the CAN Bus Analyzer PC software is being upgraded to a newer version, the firmware should be updated to match the revision level of the PC software. When updating the firmware, ensure that the Hex files are programmed into their respective PIC18F microcontrollers on the CAN Bus Analyzer hardware.

2.2.2 Upgrading the Firmware

If upgrading the firmware in the CAN Bus Analyzer, the user will need to import the Hex files into MBLAB[®] IDE and program the PIC[®] MCUs. When programming the PIC18F2680, the user may power the CAN Bus Analyzer by an external power supply or by the mini-USB cable. When programming the PIC18F550, the user needs to power the CAN Bus Analyzer by an external power supply. Additionally, when programming Hex files into PIC MCUs, it is recommended to check the firmware version from the GUI. This can be done by clicking on the [Help>About](#) menu option.

CAN Bus Analyzer User's Guide

2.3 HARDWARE INSTALLATION

2.3.1 System Requirements

- Windows® XP
- .NET Framework Version 3.5
- USB Serial Port

2.3.2 Power Requirements

- A power supply (9 to 24-Volt) is needed when operating without the PC and when updating firmware in the USB PIC MCU
- The CAN Bus Analyzer tool can also be powered using the USB port

2.3.3 Cable Requirements

- Mini-USB cable – for communicating with the PC software
- The CAN Bus Analyzer tool can be connected to a CAN network using the following:
 - Via the DB9 connector
 - Via screw-in terminals

2.3.4 Connecting the CAN Bus Analyzer to the PC and CAN Bus

1. Connect the CAN Bus Analyzer via the USB connector to the PC. You will be prompted to install the USB drivers for the tool. The drivers can be found in this location:
C:\Program Files\Microchip Technology Inc\CANAnalyzer_verXYZ
2. Connect the tool to the CAN network using the DB9 connector or the screw-in terminals. Please refer to [Figure 2-1](#) and [Figure 2-2](#) for the DB9 connector, and the screw terminals for connecting the network to the tool.

TABLE 2-1: 9-PIN (MALE) D-SUB CAN BUS PINOUT

Pin Number	Signal Name	Signal Description
1	No Connect	N/A
2	CAN_L	Dominant Low
3	GND	Ground
4	No Connect	N/A
5	No Connect	N/A
6	GND	Ground
7	CAN_H	Dominant High
8	No Connect	N/A
9	No Connect	N/A

FIGURE 2-1: PINOUT FOR THE DB9 CONNECTOR

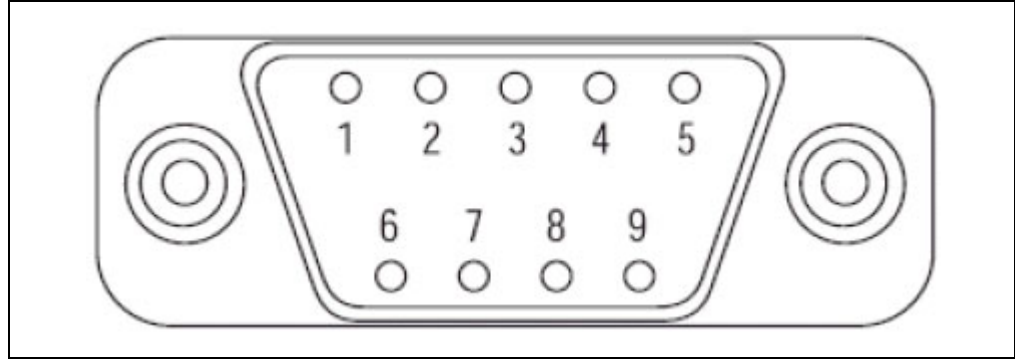
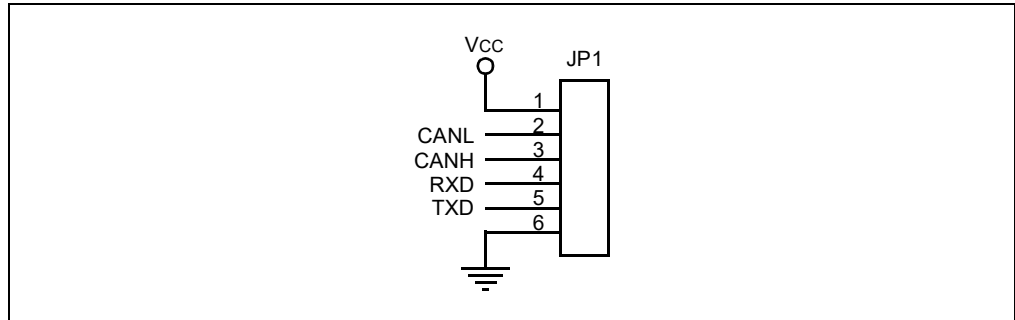

TABLE 2-2: 6-PIN SCREW CONNECTOR PINOUT

Pin Number	Signal Names	Signal Description
1	Vcc	PIC® MCU Power Supply
2	CAN_L	Dominant Low
3	CAN_H	Dominant High
4	RXD	CAN Digital Signal from Transceiver
5	TXD	CAN Digital Signal from PIC18F2680
6	GND	Ground

FIGURE 2-2: PINOUT FOR THE SCREW-IN TERMINALS



CAN Bus Analyzer User's Guide

NOTES:

Chapter 3. Using the PC GUI

Once the hardware is connected and the software is installed, open the PC GUI using the shortcut in the Programs Menu under “Microchip Technology Inc”, labeled as ‘Microchip CAN Tool ver XYZ’. [Figure 3-1](#) is a screen shot of the default view for the CAN Bus Analyzer.

FIGURE 3-1: CAN BUS ANALYZER DEFAULT VIEW

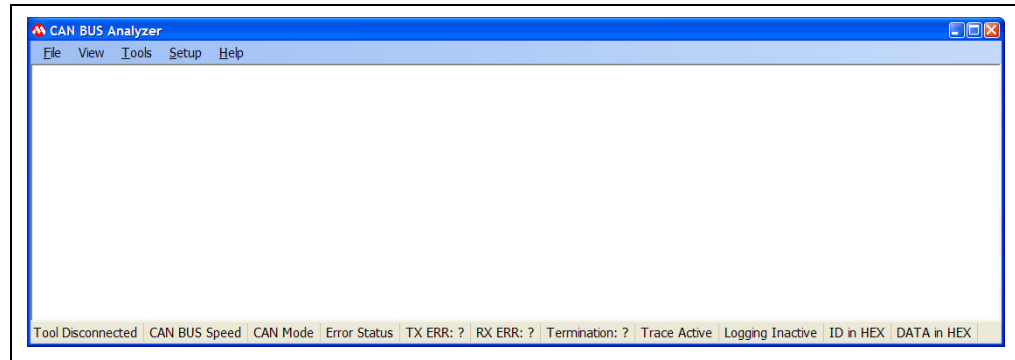

3.1 GETTING STARTED WITH A QUICK SETUP

The following are setup steps to quickly start transmitting and receiving on the CAN Bus. For more details, refer to the individual sections for the different PC GUI features.

1. Connect the CAN Bus Analyzer to the PC with the mini-USB cable.
2. Open the CAN Bus Analyzer PC GUI.
3. Open the Hardware Setup and select the CAN Bus bit rate on the CAN Bus.
4. Connect the CAN Bus Analyzer to the CAN Bus.
5. Open the Trace window.
6. Open the Transmit window.

CAN Bus Analyzer User's Guide

3.2 TRACE FEATURE

There are two types of Trace windows: Fixed and Rolling. To activate either Trace window, select the option from the main Tools menu.

FIGURE 3-2: FIXED TRACE WINDOW

TRACE	ID	DLC	DATA 0	DATA 1	DATA 2	DATA 3	DATA 4	DATA 5	DATA 6	DATA 7	TIME STAMP (sec)	TIME DELTA (sec)	COUNTER
RX	0x3D	3	0x00	0x02	0x00						194.6952	0.010	58
RX	0x10x	6	0x01	0x00	0x00	0x05	0x00	0x00			191.7632	0.010	34
RX	0x245	8	0x00	0x66	0x04	0x00	0x00	0x00	0x47	0xAA	190.3792	59.889	2
RX	0x1023x	7	0x03	0x00	0x33	0x00	0x88	0x00	0x52		196.2732	0.012	17

FIGURE 3-3: ROLLING TRACE WINDOW

TRACE	ID	DLC	DATA 0	DATA 1	DATA 2	DATA 3	DATA 4	DATA 5	DATA 6	DATA 7	TIME STAMP (sec)	TIME DELTA (sec)
RX	0x1023x	7	0x03	0x00	0x33	0x00	0x88	0x00	0x52		196.2732	0.012
RX	0x1023x	7	0x03	0x00	0x33	0x00	0x88	0x00	0x52		196.2612	0.010
RX	0x1023x	7	0x03	0x00	0x33	0x00	0x88	0x00	0x52		196.2512	0.008
RX	0x1023x	7	0x03	0x00	0x33	0x00	0x88	0x00	0x52		196.2432	0.010
RX	0x1023x	7	0x03	0x00	0x33	0x00	0x88	0x00	0x52		196.2332	0.012
RX	0x1023x	7	0x03	0x00	0x33	0x00	0x88	0x00	0x52		196.2212	0.010
RX	0x1023x	7	0x03	0x00	0x33	0x00	0x88	0x00	0x52		196.2112	0.008
RX	0x1023x	7	0x03	0x00	0x33	0x00	0x88	0x00	0x52		196.2032	0.010
RX	0x1023x	7	0x03	0x00	0x33	0x00	0x88	0x00	0x52		196.1932	0.012
RX	0x1023x	7	0x03	0x00	0x33	0x00	0x88	0x00	0x52		196.1812	0.010
RX	0x1023x	7	0x03	0x00	0x33	0x00	0x88	0x00	0x52		196.1712	0.008
RX	0x1023x	7	0x03	0x00	0x33	0x00	0x88	0x00	0x52		196.1632	0.010
RX	0x1023x	7	0x03	0x00	0x33	0x00	0x88	0x00	0x52		196.1532	0.012
RX	0x1023x	7	0x03	0x00	0x33	0x00	0x88	0x00	0x52		196.1412	0.010
RX	0x1023x	7	0x03	0x00	0x33	0x00	0x88	0x00	0x52		196.1312	0.010

The Trace window displays the CAN Bus traffic in a readable form. This window will list the ID (Extended is signified with a preceding 'x' or Standard), DLC, DATA Bytes, the Timestamp and the time difference from the last CAN Bus message on the bus. The Rolling Trace window will show the CAN messages sequentially as they appear on the CAN Bus. The time delta between messages will be based on the last received message, regardless of THE CAN ID.

The Fixed Trace window will show the CAN messages in a fixed position on the Trace window. The message will still be updated, but the time delta between messages will be based on the previous message with the same CAN ID.

3.3 TRANSMIT FEATURE

To activate the Transmit window, select “TRANSMIT” from the main Tools menu.

FIGURE 3-4: TRANSMIT WINDOW

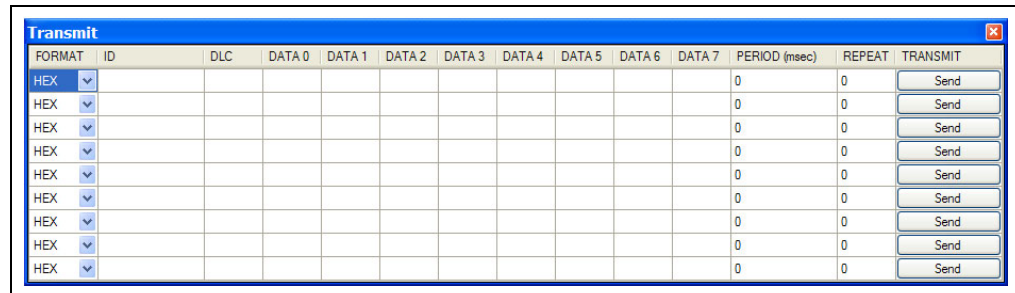

The Transmit window allows the user to interact with other nodes on the CAN Bus by transmitting messages. The user is able to enter any ID (Extended or Standard), DLC or DATA bytes combination for single message transmittal. The Transmit window also allows the user to transmit a maximum of nine separate and unique messages, either periodically, or periodically with a limited “Repeat” mode. When using the limited Repeat mode, the message will be sent out at the periodic rate for a number of “repeat” times.

3.3.1 Steps to Transmit a Single-Shot Message

1. Populate the CAN message fields, which include the ID, DLC and DATA.
2. Populate the Periodic and Repeat fields with “0”.
3. Click on the **Send** button for that row.

3.3.2 Steps to Transmit a Periodic Message

1. Populate the CAN message fields, which include the ID, DLC and DATA.
2. Populate the Periodic field (50 ms to 5000 ms).
3. Populate the Repeat field with “0” (which translates to “repeat forever”).
4. Click on the **Send** button for that row.

3.3.3 Steps to Transmit a Periodic Message with Limited Repeats

1. Populate the CAN message fields, which include the ID, DLC and DATA.
2. Populate the Periodic field (50 ms to 5000 ms).
3. Populate the Repeat field (with a value from 1 to 10).
4. Click on the **Send** button for that row.

CAN Bus Analyzer User's Guide

3.4 HARDWARE SETUP FEATURE

To activate the Hardware Setup window, select “HARDWARE SETUP” from the main Tools menu.

FIGURE 3-5: HARDWARE SETUP WINDOW

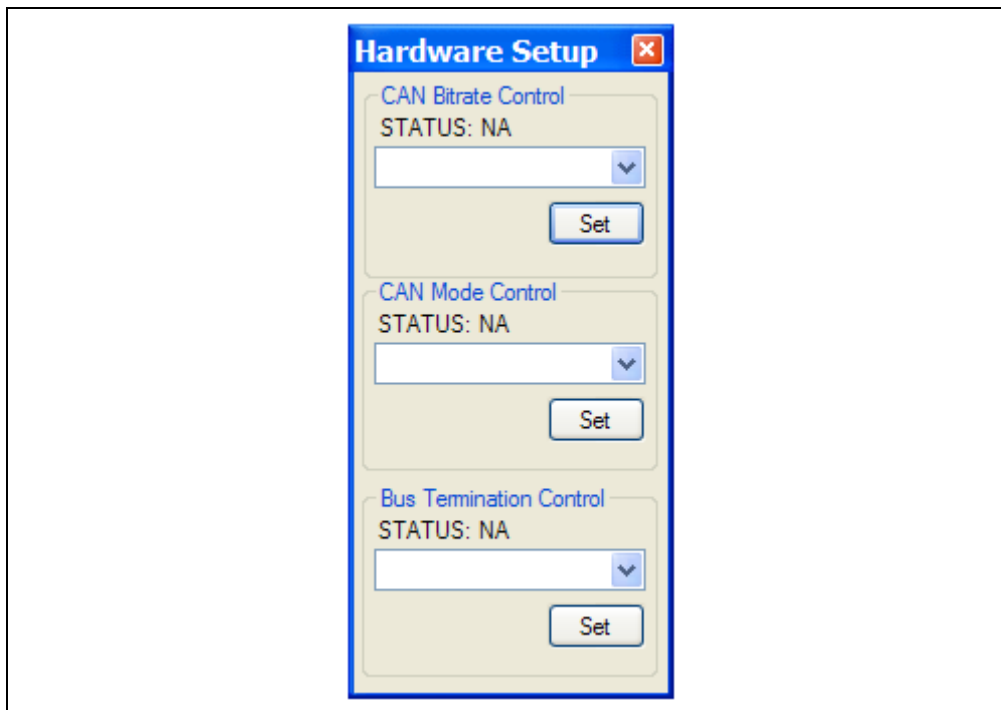

The Hardware Setup window allows the user to set up the CAN Bus Analyzer for communication on the CAN Bus. This feature also gives the user the ability to quickly test the hardware on the CAN Bus Analyzer.

To set up the tool to communicate on the CAN Bus:

1. Select the CAN bit rate from the drop-down combo box.
2. Click the **Set** button. Confirm that the bit rate has changed by viewing the bit rate setting on the bottom of the main CAN Bus Analyzer window.
3. If the CAN Bus needs the termination resistor active, then turn it on by clicking the **Turn On** button for the Bus Termination.

Test the CAN Bus Analyzer hardware:

1. Ensure that the CAN Bus Analyzer is connected. You can confirm this by viewing the tool connection status on the status strip on the bottom of the main CAN Bus Analyzer window.
2. To confirm that the communication is working between the USB PIC[®] MCU and the CAN PIC MCU, click on the *Help->About* main menu option to view the version numbers of the firmware loaded into each PIC MCU.

Appendix A. Error Messages

In this section, the various “pop-up” errors that are found in the GUI will be discussed in detail as to why they may occur, and the possible solutions for correcting the errors.

TABLE A-1: ERROR MESSAGES

Error Number	Error	Possible Solution
1.00.x	Trouble reading the USB firmware version	Unplug/plug the tool into the PC. Also make sure that the PIC18F2550 is programmed with the proper Hex file.
2.00.x	Trouble reading the CAN firmware version	Unplug/plug the tool into the PC. Also make sure that the PIC18F2680 is programmed with the proper Hex file.
3.00.x	ID field is empty	The value in the ID field can not be empty for a message that a user is requesting to be transmitted. Enter a valid value.
3.10.x	DLC field is empty	The value in the DLC field can not be empty for a message that a user is requesting to be transmitted. Enter a valid value.
3.20.x	DATA field is empty	The value in the DATA field can not be empty for a message that a user is requesting to be transmitted. Enter a valid value. Remember, the DLC value drives how many data bytes will be sent.
3.30.x	PERIOD field is empty	The value in the PERIOD field can not be empty for a message that a user is requesting to be transmitted. Enter a valid value.
3.40.x	REPEAT field is empty	The value in the REPEAT field can not be empty for a message that a user is requesting to be transmitted. Enter a valid value.
4.00.x	Enter the Extended ID within the following range (0x-1FFFFFFFx)	Enter a valid ID into the TEXT field. The tool is expecting a hexadecimal value for an Extended ID in the range of “0x-1FFFFFFFx”. When entering an Extended ID, make sure to append ‘x’ onto the ID.
4.02.x	Enter the Extended ID within the following range (0x-536870911x)	Enter a valid ID into the TEXT field. The tool is expecting a decimal value for an Extended ID in the range of “0x-536870911x”. When entering an Extended ID, make sure to append ‘x’ onto the ID.
4.04.x	Enter the Standard ID within the following range (0-7FF)	Enter a valid ID into the TEXT field. The tool is expecting a hexadecimal value for a Standard ID in the range of “0-7FF”. When entering a Standard ID, make sure to append ‘x’ onto the ID.
4.06.x	Enter the Standard ID within the following range (0-2047)	Enter a valid ID into the TEXT field. The tool is expecting a decimal value for a Standard ID in the range of “0-2048”. When entering a Standard ID, make sure to append ‘x’ onto the ID.
4.10.x	Enter DLC within the following range (0-8)	Enter a valid DLC into the TEXT field. The tool is expecting a value in the range of “0-8”.
4.20.x	Enter DATA within the following range (0-FF)	Enter valid data into the TEXT field. The tool is expecting a hexadecimal value in the range of “0-FF”.

CAN Bus Analyzer User's Guide

TABLE A-1: ERROR MESSAGES (CONTINUED)

Error Number	Error	Possible Solution
4.25.x	Enter DATA within the following range (0-255)	Enter valid data into the TEXT field. The tool is expecting a decimal value in the range of "0-255".
4.30.x	Enter a valid PERIOD within the following range (100-5000)\nOr (0) for a one-shot message	Enter a valid period into the TEXT field. The tool is expecting a decimal value in the range of "0 or 100-5000".
4.40.x	Enter a valid REPEAT within the following range (1-99)\nOr (0) for a one-shot message	Enter a valid repeat into the TEXT field. The tool is expecting a decimal value in the range of "0-99".
4.70.x	Unknown error caused by user input	Check that the TEXT field only has no special characters or spaces.
4.75.x	Required input for CAN Message is empty	Check that the ID, DLC, DATA, PERIOD and REPEAT fields contain valid data.
5.00.x	Reserved for Message Received errors	Reserved for Message Received errors.
6.00.x	Unable to Log Data	Tool is unable to write CAN traffic to Log File. Possible cause may be that the drive is either full, write-protected or does not exist.

NOTES:



MICROCHIP

Worldwide Sales and Service

AMERICAS

Corporate Office
2355 West Chandler Blvd.
Chandler, AZ 85224-6199
Tel: 480-792-7200
Fax: 480-792-7277
Technical Support:
<http://www.microchip.com/support>
Web Address:
www.microchip.com

Atlanta

Duluth, GA
Tel: 678-957-9614
Fax: 678-957-1455

Austin, TX

Tel: 512-257-3370

Boston

Westborough, MA
Tel: 774-760-0087
Fax: 774-760-0088

Chicago

Itasca, IL
Tel: 630-285-0071
Fax: 630-285-0075

Dallas

Addison, TX
Tel: 972-818-7423
Fax: 972-818-2924

Detroit

Novi, MI
Tel: 248-848-4000

Houston, TX

Tel: 281-894-5983

Indianapolis

Noblesville, IN
Tel: 317-773-8323
Fax: 317-773-5453
Tel: 317-536-2380

Los Angeles

Mission Viejo, CA
Tel: 949-462-9523
Fax: 949-462-9608
Tel: 951-273-7800

Raleigh, NC

Tel: 919-844-7510

New York, NY

Tel: 631-435-6000

San Jose, CA

Tel: 408-735-9110
Tel: 408-436-4270

Canada - Toronto

Tel: 905-695-1980
Fax: 905-695-2078

ASIA/PACIFIC

Australia - Sydney
Tel: 61-2-9868-6733

China - Beijing
Tel: 86-10-8569-7000

China - Chengdu
Tel: 86-28-8665-5511

China - Chongqing
Tel: 86-23-8980-9588

China - Dongguan
Tel: 86-769-8702-9880

China - Guangzhou
Tel: 86-20-8755-8029

China - Hangzhou
Tel: 86-571-8792-8115

China - Hong Kong SAR
Tel: 852-2943-5100

China - Nanjing
Tel: 86-25-8473-2460

China - Qingdao
Tel: 86-532-8502-7355

China - Shanghai
Tel: 86-21-3326-8000

China - Shenyang
Tel: 86-24-2334-2829

China - Shenzhen
Tel: 86-755-8864-2200

China - Suzhou
Tel: 86-186-6233-1526

China - Wuhan
Tel: 86-27-5980-5300

China - Xian
Tel: 86-29-8833-7252

China - Xiamen
Tel: 86-592-2388138

China - Zhuhai
Tel: 86-756-3210040

ASIA/PACIFIC

India - Bangalore
Tel: 91-80-3090-4444

India - New Delhi
Tel: 91-11-4160-8631

India - Pune
Tel: 91-20-4121-0141

Japan - Osaka
Tel: 81-6-6152-7160

Japan - Tokyo
Tel: 81-3-6880-3770

Korea - Daegu
Tel: 82-53-744-4301

Korea - Seoul
Tel: 82-2-554-7200

Malaysia - Kuala Lumpur
Tel: 60-3-7651-7906

Malaysia - Penang
Tel: 60-4-227-8870

Philippines - Manila
Tel: 63-2-634-9065

Singapore
Tel: 65-6334-8870

Taiwan - Hsin Chu
Tel: 886-3-577-8366

Taiwan - Kaohsiung
Tel: 886-7-213-7830

Taiwan - Taipei
Tel: 886-2-2508-8600

Thailand - Bangkok
Tel: 66-2-694-1351

Vietnam - Ho Chi Minh
Tel: 84-28-5448-2100

EUROPE

Austria - Wels
Tel: 43-7242-2244-39
Fax: 43-7242-2244-393

Denmark - Copenhagen
Tel: 45-4485-5910
Fax: 45-4485-2829

Finland - Espoo
Tel: 358-9-4520-820

France - Paris
Tel: 33-1-69-53-63-20
Fax: 33-1-69-30-90-79

Germany - Garching
Tel: 49-8931-9700

Germany - Haan
Tel: 49-2129-3766400

Germany - Heilbronn
Tel: 49-7131-72400

Germany - Karlsruhe
Tel: 49-721-625370

Germany - Munich
Tel: 49-89-627-144-0
Fax: 49-89-627-144-44

Germany - Rosenheim
Tel: 49-8031-354-560

Israel - Ra'anana
Tel: 972-9-744-7705

Italy - Milan
Tel: 39-0331-742611
Fax: 39-0331-466781

Italy - Padova
Tel: 39-049-7625286

Netherlands - Drunen
Tel: 31-416-690399
Fax: 31-416-690340

Norway - Trondheim
Tel: 47-7288-4388

Poland - Warsaw
Tel: 48-22-3325737

Romania - Bucharest
Tel: 40-21-407-87-50

Spain - Madrid
Tel: 34-91-708-08-90
Fax: 34-91-708-08-91

Sweden - Gothenberg
Tel: 46-31-704-60-40

Sweden - Stockholm
Tel: 46-8-5090-4654

UK - Wokingham
Tel: 44-118-921-5800
Fax: 44-118-921-5820